

**PARTICULARS TO APPEAR ON THE OUTER PACKAGE {Box with a 50 ml  
bottle and Box with a 100 ml bottle }**

**1. NAME OF THE VETERINARY MEDICINAL PRODUCT**

Urixine 40 mg/ml syrup

**2. STATEMENT OF ACTIVE SUBSTANCES**

Each ml contains:

**Active substance:**

Phenylpropanolamine      40.28 mg  
(equivalent to 50 mg of Phenylpropanolamine hydrochloride).

**3. PACKAGE SIZE**

1x50 ml

1x100 ml

**4. TARGET SPECIES**

Dogs.

**5. INDICATIONS**

**6. ROUTES OF ADMINISTRATION**

Oral use.

**7. WITHDRAWAL PERIODS**

Not applicable.

**8. EXPIRY DATE**

Exp. {mm/yyyy}

Once opened use by 3 months.

**9. SPECIAL STORAGE PRECAUTIONS**

**10. THE WORDS “READ THE PACKAGE LEAFLET BEFORE USE”**

Read the package leaflet before use.

**11. THE WORDS “FOR ANIMAL TREATMENT ONLY”**

For animal treatment only.

**12. THE WORDS “KEEP OUT OF THE SIGHT AND REACH OF CHILDREN”**

Keep out of the sight and reach of children.

**13. NAME OF THE MARKETING AUTHORISATION HOLDER**

Alivira Animal Health UK Ltd

**14. MARKETING AUTHORISATION NUMBERS**

Vm 54375/5001

**15. BATCH NUMBER**

Lot {number}

**PARTICULARS TO APPEAR ON THE IMMEDIATE PACKAGE { Label of 100 ml  
bottle }**

**1. NAME OF THE VETERINARY MEDICINAL PRODUCT**

Urixine 40 mg/ml syrup

**2. STATEMENT OF ACTIVE SUBSTANCES**

Each ml contains:

**Active substance:**

Phenylpropanolamine      40.28 mg  
(equivalent to 50 mg of Phenylpropanolamine hydrochloride).

**3. TARGET SPECIES**

Dogs.

**4. ROUTES OF ADMINISTRATION**

Oral use.  
Read the package leaflet before use.

**5. WITHDRAWAL PERIODS**

Not applicable.

**6. EXPIRY DATE**

Exp. {mm/yyyy}  
Once opened use by 3 months.

**7. SPECIAL STORAGE PRECAUTIONS**

**8. NAME OF THE MARKETING AUTHORISATION HOLDER**

Alivira Animal Health UK Ltd

**9. BATCH NUMBER**

Lot {number}

**MINIMUM PARTICULARS TO APPEAR ON SMALL IMMEDIATE PACKAGING  
UNITS { Label of 50 ml bottle }**

**1. NAME OF THE VETERINARY MEDICINAL PRODUCT**

Urixine

**2. QUANTITATIVE PARTICULARS OF THE ACTIVE SUBSTANCES**

Each ml contains:

**Active substance:**

Phenylpropanolamine .....40.28 mg  
(equivalent to 50 mg of Phenylpropanolamine hydrochloride).

**3. BATCH NUMBER**

Lot {number}

**4. EXPIRY DATE**

Exp. {mm/yyyy}

Once opened use by 3 months.

**PARTICULARS TO APPEAR ON THE PACKAGE LEAFLET:**

**PACKAGE LEAFLET**

**1. Name of the veterinary medicinal product**

Urixine 40 mg/ml syrup for dogs

**2. Composition**

Each ml contains:

**Active substance:**

Phenylpropanolamine .....40.28 mg  
(equivalent to 50 mg of Phenylpropanolamine hydrochloride).

**3. Target species**

Dogs.

**4. Indications for use**

Treatment of urinary incontinence associated with urethral sphincter incompetence in the bitch.

Efficacy has been only demonstrated with ovariohysterectomised bitches.

**5. Contraindications**

Do not administer to patients treated with non-selective monoamine oxidase inhibitors.

Do not use in cases of hypersensitivity to the active substance or to any of the excipients.

**6. Special warnings**

Special warnings:

The use of the veterinary medicinal product is not appropriate for the treatment of behavioural causes of inappropriate urination.

In bitches less than 1 year old the possibility of anatomical disorders contributing to incontinence should be considered prior to treatment.

Special precautions for safe use in the target species:

Phenylpropanolamine, a sympathomimetic drug, may affect the cardiovascular system, especially blood pressure and heart rate, and should be used with caution in animals with cardiovascular diseases.

Care should be exercised in treating animals with severe renal or hepatic insufficiency, diabetes mellitus, hyperadrenocorticism, glaucoma, hyperthyroidism or other metabolic disorders.

Special precautions to be taken by the person administering the veterinary medicinal product to animals:

Phenylpropanolamine Hydrochloride is toxic when ingested in higher doses. Adverse effects may include dizziness, headache, nausea, insomnia or restlessness, and increased blood pressure. Higher doses may be fatal, especially in children.

Avoid oral ingestion including hand-to-mouth contact.

To avoid accidental ingestion, the veterinary medicinal product should be used and stored out of sight and reach of children. Always close the cap tightly after use to ensure the child-resistant closure works correctly. Do not leave a filled syringe unattended.

In case of accidental ingestion, seek medical advice immediately and show the package leaflet or the label to the physician. Wash hands after handling the veterinary medicinal product.

This veterinary medicinal product may cause skin and eye irritation. Avoid skin and eye contact.

In case of accidental skin contact, wash the contaminated area with soap and water.

In case of accidental eye contact, rinse the eye thoroughly with clean water and consult a physician if irritation persists.

People with known hypersensitivity (allergy) to phenylpropanolamine hydrochloride should avoid contact with the veterinary medicinal product. Wear gloves. If allergic symptoms develop, such as a skin rash, swelling of the face, lips or eyes or difficulty in breathing, you should seek medical attention immediately and show the package leaflet or label to the physician.

Special precautions for the protection of the environment:

Not applicable

Pregnancy and lactation:

Do not use during pregnancy or lactation.

Interaction with other medicinal products and other forms of interaction:

Care should be exercised in administering the veterinary medicinal product with other sympathomimetic drugs, anticholinergic drugs, tricyclic antidepressants or specific type B monoamine oxidase inhibitors.

Overdose:

In healthy dogs, no side effects were observed at up to 5 times the recommended dosage. However, an overdose of phenylpropanolamine could produce symptoms of excessive stimulation of the sympathetic nervous system. Treatment should be symptomatic. Alpha-adrenergic blockers may be appropriate in the case of severe overdose. However, no specific recommendation on drugs or dosages can be given.

Major incompatibilities:

In the absence of compatibility studies, this veterinary medicinal product must not be mixed with other veterinary medicinal products.

## 7. Adverse events

Dogs:

Rare (more than 1 but less than 10 animals in 10,000 animals treated)	Loose stools <sup>1</sup> , liquid diarrhoea <sup>1</sup> Emesis, lethargy
Very rare (<1 animal / 10,000 animals treated, including isolated reports):	Decreased appetite <sup>1</sup> , collapse Dizziness, ataxia Increased blood pressure, increased heart rate, Arrhythmia <sup>1</sup> Hyperactivity (including restlessness), aggression Polyuria, polydipsia Hypersensitivity reaction Seizure

<sup>1</sup>Treatment can be continued depending on the severity of the undesirable effect observed.

Sympathomimetics can produce a wide variety of effects, many of which mimic the reactions of excessive stimulation of the sympathetic nervous system which can induce proteinuria.

Reporting adverse events is important. It allows continuous safety monitoring of a product. If you notice any side effects, even those not already listed in this package leaflet, or you think that the medicine has not worked, please contact, in the first instance, your veterinarian. You can also report any adverse events to the marketing authorisation holder or the local representative of the marketing authorisation holder using the contact details at the end of this leaflet, or via your national reporting system at:

Website: <https://www.gov.uk/report-veterinary-medicine-problem/animal-reacts-medicine>

e-mail: [adverse.events@vmd.gov.uk](mailto:adverse.events@vmd.gov.uk)

## 8. Dosage for each species, routes and method of administration

Oral use.

The recommended dose is 1 mg of phenylpropanolamine/kg b.w. 3 times a day, with food (equivalent to 0.1 ml of veterinary medicinal product for every 5 kg b.w. 3 times a day).

Absorption of the veterinary medicinal product is increased when administered to dogs in an empty stomach.

To ensure a correct dosage, body weight should be determined as accurately as possible..

### 9. Advice on correct administration

#### INSTRUCTIONS FOR USE



**1.** Remove the child resistant cap by pressing down firmly and turning it to the left.

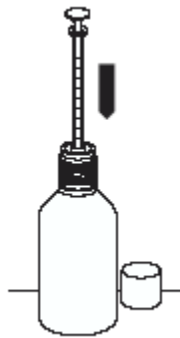

**2.** Take the dispenser with the plunger all the way down and insert the tip into the cap opening. Push down decisively.

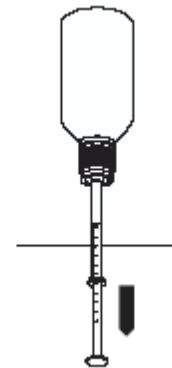

**3.** Invert the bottle and, holding the dispenser, pull the plunger towards you while slowly drawing veterinary medicinal product into the dispenser to avoid the formation of air bubbles. Stop at the mark on the plunger corresponding to the required volume of veterinary medicinal product.



**4.** Upright the bottle and grasp the bottom of the dispenser, near the neck of the bottle. Remove the dispenser from the bottle with a careful twisting motion.

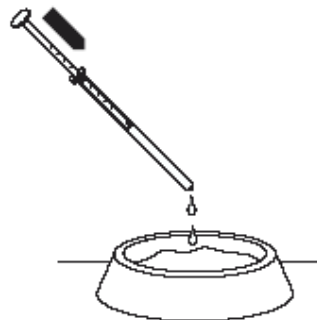

**5.** Hold the dispenser over the dog's food and push the plunger down to ensure that the full dose of veterinary medicinal product is used.

**6.** Replace the cap on the bottle and twist clockwise to close. Store the bottle in a safe place, at room temperature, out of the reach of children.



7. Before placing the dispenser in a clean place, dry the tip with a clean cloth or paper. Wash the dispenser by removing the plunger and rinse both elements with hot water.

8. Dry it carefully, making sure the inside of the dispenser is dry before reinserting the plunger.

## **10. Withdrawal periods**

Not applicable.

## **11. Special storage precautions**

Keep out of the sight and reach of children.

This veterinary medicinal product does not require any special storage conditions.

Do not use this veterinary medicinal product after the expiry date which is stated on the label after Exp. The expiry date refers to the last day of that month.

Shelf life after first opening the immediate packaging: 3 months

## **12. Special precautions for disposal**

Medicines should not be disposed of via wastewater.

Use take-back schemes for the disposal of any unused veterinary medicinal product or waste materials derived thereof in accordance with local requirements and with any applicable national collection systems. These measures should help to protect the environment.

Ask your veterinary surgeon or pharmacist how to dispose of medicines no longer required.

## **13. Classification of veterinary medicinal products**

Veterinary medicinal product subject to prescription.

## **14. MARKETING AUTHORISATION NUMBERS AND PACK SIZES**

Vm 54375/5001

### Package size:

Box with a 50 ml bottle and a dosing syringe

Box with a 100 ml bottle and a dosing syringe

Not all pack sizes may be marketed.

## 15. PID link (Do not print heading)

Find more product information by searching for the 'Product Information Database' on [www.gov.uk](http://www.gov.uk).

## 16. Contact details

Marketing authorisation holder and contact details to report suspected adverse reactions:

Alivira Animal Health UK Ltd  
Hygeia Building, Rear Ground Floor  
66-68 College Road  
Harrow  
Middlesex  
HA1 1BE  
United Kingdom

Manufacturers responsible for batch release:

Laboratorios Karizoo, S.A.  
Pol. Ind. La Borda  
Mas Pujades, 11-12  
08140 Caldes de Montbui (Barcelona)  
Spain

FATRO S.p.A.  
Via Emilia 285  
40064 Ozzano dell'Emilia  
(Bologna) Italia

## 17. Other information

### Pharmacodynamics

Phenylpropanolamine hydrochloride is a sympathomimetic agent which acts by direct stimulation of the smooth muscle of the internal urethral sphincter. It is an analogue of the endogenous sympathomimetic amines.

Phenylpropanolamine hydrochloride has weak sympathomimetic activity and produces a wide range of pharmacological effects. It appears to act directly on the smooth muscle of the lower urinary tract. The smooth muscle is thought to be largely responsible for the maintenance of tone in the resting state.

The clinical effect of phenylpropanolamine in urinary incontinence is based on its stimulation effect on  $\alpha$ -adrenergic receptors. This causes an increase in, and a stabilisation of, the closure pressure in the urethra, which is innervated mainly by adrenergic nerves.

Phenylpropanolamine is a racemic mixture of D and L enantiomers.

### **Pharmacokinetics**

In the dog, the mean half-life of Phenylpropanolamine is approximately 3 hours with maximal plasma concentrations being found after approximately 1 hour.

No accumulation of phenylpropanolamine has been observed after a dose of 1 mg/kg 3 times daily over 15 days.

When the veterinary medicinal product is administered to a fasted dog, bioavailability is increased significantly.

POM-V

*Gavin Hall*

Approved: 17 January 2025