

ANNEX III
LABELLING AND PACKAGE LEAFLET

A. LABELLING

PARTICULARS TO APPEAR ON THE OUTER PACKAGE
(CARDBOARD CARTON)

1. NAME OF THE VETERINARY MEDICINAL PRODUCT

Animeloxan 1.5 mg/ml oral suspension

2. STATEMENT OF ACTIVE SUBSTANCES

Each ml contains:

Active substance:
Meloxicam 1.5 mg

3. PACKAGE SIZE

10 ml bottle
25 ml bottle
50 ml bottle
100 ml bottle
125 ml bottle

A measuring device (a plastic syringe) is also included in the pack.

4. TARGET SPECIES

Dogs

5. INDICATIONS

6. ROUTES OF ADMINISTRATION

Shake well before use.
To be administered mixed with food or directly into the mouth.
Read the package leaflet before use.

7. WITHDRAWAL PERIODS

8. EXPIRY DATE

Exp. {mm/yyyy}
Shelf-life after first opening the immediate packaging: 6 months
Once opened, use by:

9. SPECIAL STORAGE PRECAUTIONS

10. THE WORDS “READ THE PACKAGE LEAFLET BEFORE USE”

Read the package leaflet before use.

11. THE WORDS “FOR ANIMAL TREATMENT ONLY”

For animal treatment only.

12. THE WORDS “KEEP OUT OF THE SIGHT AND REACH OF CHILDREN”

Keep out of the sight and reach of children.

13. NAME OF THE MARKETING AUTHORISATION HOLDER

aniMedica GmbH

14. MARKETING AUTHORISATION NUMBERS

Vm 24745/3000

15. BATCH NUMBER

Lot {number}

**PARTICULARS TO APPEAR ON THE IMMEDIATE PACKAGE
(100 ml, 125 ml)**

VIA ADHESIVE LABEL ON BOTTLE

1. NAME OF THE VETERINARY MEDICINAL PRODUCT

Animeloxan 1.5 mg/ml, oral suspension

2. STATEMENT OF ACTIVE SUBSTANCES

Each ml contains:

Active substance:
Meloxicam 1.5 mg

3. TARGET SPECIES

Dogs

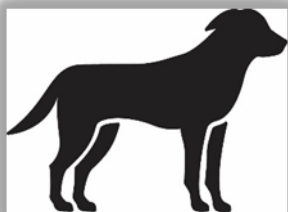

(a pictogram may be used to replace the wording)

4. ROUTES OF ADMINISTRATION

Shake well before use.
To be administered mixed with food or directly into the mouth.
Read the package leaflet before use.

5. WITHDRAWAL PERIODS

6. EXPIRY DATE

Exp. {mm/yyyy}
Shelf-life after first opening the immediate packaging: 6 months
Once opened, use by:

7. SPECIAL STORAGE PRECAUTIONS

8. NAME OF THE MARKETING AUTHORISATION HOLDER

aniMedica GmbH

9. BATCH NUMBER

Lot {number}

**MINIMUM PARTICULARS TO APPEAR ON SMALL IMMEDIATE PACKAGING
UNITS (10 ml, 25 ml, 50ml)**

VIA ADHESIVE LABEL ON BOTTLE

1. NAME OF THE VETERINARY MEDICINAL PRODUCT

Animeloxan
Dogs



(a pictogram may be used to replace the wording)

2. QUANTITATIVE PARTICULARS OF THE ACTIVE SUBSTANCES

Meloxicam 1.5 mg/ml

3. BATCH NUMBER

Lot {number}

4. EXPIRY DATE

Exp. {mm/yyyy}

Shelf-life after first opening the immediate packaging: 6 months

Once opened, use by:

B. PACKAGE LEAFLET

PACKAGE LEAFLET

1. Name of the veterinary medicinal product

Animeloxan 1.5 mg/ml oral suspension for dogs

2. Composition

Each ml contains:

Active substance:
Meloxicam 1.5 mg

Excipient:
Sodium benzoate 1.5 mg

Pale yellow viscous suspension.

3. Target species

Dogs

4. Indications for use

Meloxicam is a Non Steroidal Anti-Inflammatory Drug (NSAID) that alleviates inflammation and pain in both acute and chronic musculo-skeletal disorders.

5. Contraindications

- Do not use in pregnant or lactating animals.
- Do not use in animals suffering from gastrointestinal disorders such as irritation and haemorrhage, impaired hepatic, cardiac or renal function and haemorrhagic disorders.
- Do not use in cases of hypersensitivity to the active substance or to any of the excipients.
- Do not use in dogs less than 6 weeks of age.

6. Special warnings

Special warnings:

None.

Special precautions for safe use in the target species:

If side effects occur, treatment should be discontinued and the advice of a veterinarian should be sought. Avoid use in any dehydrated, hypovolaemic or hypotensive animal, as there is a potential risk of increased renal toxicity. In case of prolonged use, monitoring during treatment should be carried out.

Special precautions to be taken by the person administering the veterinary medicinal product to animals:

People with known hypersensitivity to NSAIDs should avoid contact with the veterinary medicinal product.

In case of accidental ingestion, seek medical advice immediately and show this package leaflet or the label to the physician.

Pregnancy and lactation:

The safety of the veterinary medicinal product has not been established during pregnancy or lactation.

Pregnancy:

Do not use during pregnancy.

Lactation:

Do not use for nursing bitches.

Interaction with other medicinal products and or other form of interaction:

Other NSAIDs, diuretics, anticoagulants, aminoglycoside antibiotics and substances with high protein binding may compete for binding and thus lead to toxic effects. Meloxicam must not be administered in conjunction with other NSAIDs or glucocorticosteroids.

Pre-treatment with anti-inflammatory substances may result in additional or increased adverse effects and accordingly a treatment-free period with such drugs should be observed for at least 24 hours before commencement of treatment. The treatment-free period, however, should take into account the pharmacokinetic properties of the veterinary medicinal products used previously.

Meloxicam may antagonise the antihypertensive effects of ACE inhibitors.

Overdose:

In the case of overdosage symptomatic treatment should be initiated.

Major incompatibilities:

In the absence of compatibility studies, this veterinary medicinal product must not be mixed with other veterinary medicinal products.

7. Adverse events

Dog:

Undetermined frequency (cannot be estimated from the available data):
Appetite loss¹, vomiting¹, diarrhoea¹, blood in faeces^{1,2}, apathy¹

¹These typical adverse drug reactions of NSAIDs occur occasionally and generally within the first treatment week and are in most cases transient and disappear following termination of the treatment but in very rare cases may be serious or fatal.
²occult

Reporting adverse events is important. It allows continuous safety monitoring of a product. If you notice any side effects, even those not already listed in this package leaflet, or you think that the medicine has not worked, please contact, in the first instance, your veterinarian. You can also report any adverse events to the marketing authorisation holder or the local representative of the marketing authorisation holder using the contact details at the end of this leaflet, or via your national reporting system: {national system details}.

8. Dosage for each species, routes and method of administration

Dosage

Initial treatment is a single dose of 0.2 mg meloxicam/kg body weight on the first day. Treatment is to be continued once daily by oral administration (at 24-hour intervals) at a maintenance dose of 0.1 mg meloxicam/kg body weight (equivalent to 0,07 ml/kg).

Method and route of administration

Shake well before use. To be administered mixed with food or directly into the mouth.

The suspension can be given using the measuring syringe provided in the package (see below).

The syringe provided allows dosing for dogs with a body weight of 2.5 – 45 kg. For dosing for dogs with a body weight of less than 2.5 kg, a syringe with a smaller volume (0.5 ml, 1 ml) must be used.

The syringe fits onto the bottle and has a kg-body weight scale which corresponds to the maintenance dose (i.e. 0.1 mg meloxicam/kg body weight corresponds to 0,07 ml/kg bodyweight). Thus for the first day, twice the maintenance volume will be required.

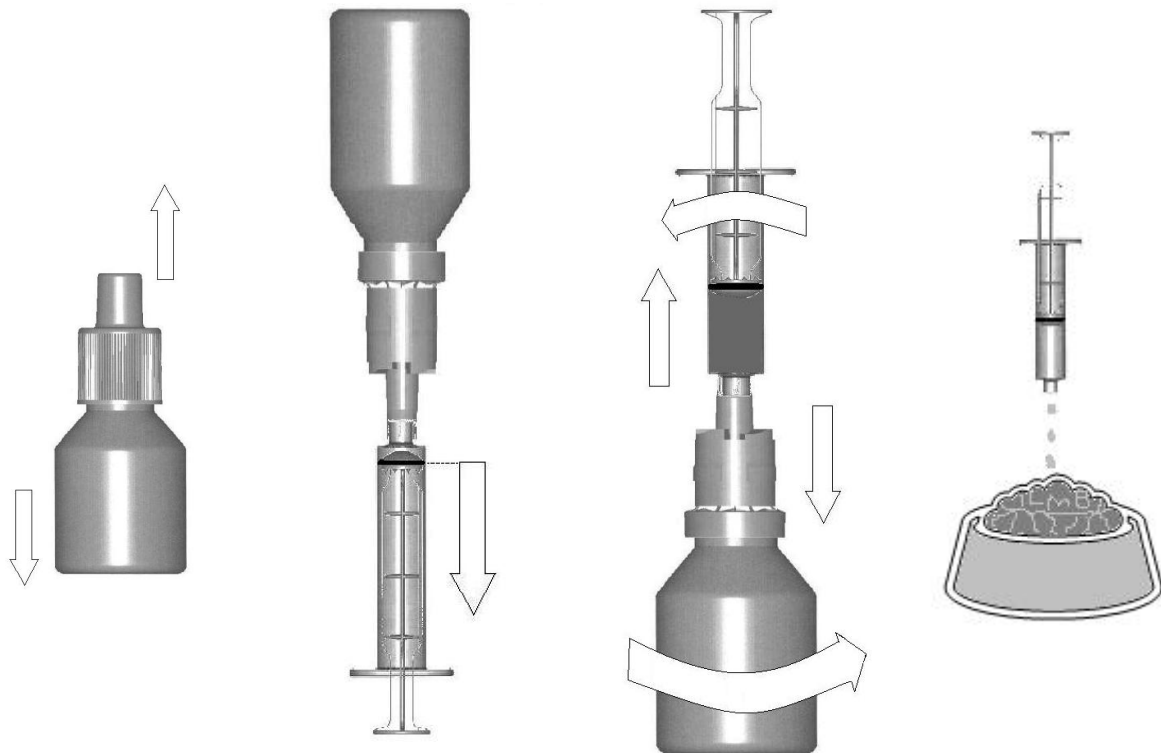

Shake bottle well. Push down and unscrew bottle top. Attach the dosing syringe to the bottle by gently pushing the end onto the top of the bottle.

Turn the bottle/syringe upside down. Pull the plunger out until the line on the plunger corresponds to your dog's bodyweight in kilograms

Turn the bottle right way up and with a twisting movement separate the dosing syringe from the bottle

Empty the contents of the syringe onto the food or directly into the mouth by pushing the plunger in.

A clinical response is normally seen within 3 - 4 days. Treatment should be discontinued after 10 days at the latest if no clinical improvement is apparent.

For longer term treatment, once clinical response has been observed (after ≥ 4 days), the dose of the veterinary medicinal product can be adjusted to the lowest effective individual dose reflecting that the degree of pain and inflammation associated with chronic musculo-skeletal disorders may vary over time.

Avoid introduction of contamination during use.

9. Advice on correct administration

Particular care should be taken with regard to the accuracy of dosing. Please carefully follow the instructions of the veterinarian.

The date of first use (on first opening of the bottle) should be recorded on the space provided on the label or carton, along with the expiry date of the opened bottle (six months from the date of opening). Any unused veterinary medicinal product should be discarded after this date.

10. Withdrawal periods

Not applicable.

11. Special storage precautions

Keep out of the sight and reach of children.
This veterinary medicinal product does not require any special storage conditions.

After each dose, the tip of the syringe should be wiped and the bottle cap screwed back on tightly. The syringe should be stored in the carton box in between uses.

Shelf-life after first opening the immediate packaging: 6 months.

Do not use after the expiry date stated on the carton and the bottle.
The expiry date refers to the last day of that month.

12. Special precautions for disposal

Medicines should not be disposed of via wastewater or household waste.

Use take-back schemes for the disposal of any unused veterinary medicinal product or waste materials derived thereof in accordance with local requirements and with any applicable national collection systems. These measures should help to protect the environment.

Ask your veterinary surgeon or pharmacist how to dispose of medicines no longer required.

13. Classification of veterinary medicinal products

Veterinary medicinal product subject to prescription.

14. Marketing authorisation numbers and pack sizes

Vm 24745/3000

10 ml, 25 ml, 50 ml, 100 ml or 125 ml bottle.

Not all pack sizes may be marketed.

15. Date on which the package leaflet was last revised

August 2023

Detailed information on this veterinary medicinal product is available in the Union Product Database (<https://medicines.health.europa.eu/veterinary>).

16. Contact details

Marketing authorisation holder and manufacturer responsible for batch release and contact details to report suspected adverse reactions:

Error! Reference source not found.
Error! Reference source not found.
Error! Reference source not found.
Error! Reference source not found.
Tel: +49-2536-3302-0

Local representatives and contact details to report suspected adverse reactions:

For any information about this veterinary medicinal product, please contact the local representative of the marketing authorisation holder.

17. Other information

Approved 23 Approved 2024

A handwritten signature in black ink, appearing to read "Hunter.", is positioned below the approval text.