

SUMMARY OF PRODUCT CHARACTERISTICS

1. NAME OF THE VETERINARY MEDICINAL PRODUCT

PolyVar Yellow 275 mg bee-hive strip

2. QUALITATIVE AND QUANTITATIVE COMPOSITION

One bee-hive strip contains

Active substance:

Flumethrin 275 mg

Excipients:

For the full list of excipients, see section 6.1.

3. PHARMACEUTICAL FORM

Bee-hive strip

Yellow, plastic strips with 15 holes

4. CLINICAL PARTICULARS

4.1 Target species

Honey bee (*Apis mellifera*)

4.2 Indications for use, specifying the target species

For the treatment of varroosis in honey bees caused by flumethrin sensitive *Varroa destructor* mites.

4.3 Contraindications

Do not use in cases of known resistance against pyrethroids as described in section 4.4, Special warnings.

4.4 Special warnings for each target species

All colonies located on the same apiary should be treated simultaneously.

The product should be used as part of an integrated varroa control programme.

As an effective method to reduce the risk of resistance selection PolyVar Yellow – as for other acaricides – should not be used in consecutive years. Instead, strict rotation with products containing active substances from other chemical classes should be applied. Depending on the regional resistance situation a longer treatment break than one year may be necessary. As flumethrin and tau-fluvalinate belong to the same class they are not suitable for rotation with each other.

Inappropriate use of the product could result in an increased risk of resistance development and could ultimately result in ineffective therapy and colony losses.

In general, it is recommended to test acaricide susceptibility at a regional level, e.g. by bioassays or molecular analysis (PCR). In the case of existing resistance to pyrethroids PolyVar Yellow should not be applied. Where resistance to pyrethroids has been seen in the past, retesting of the current status of the colony should be considered as reversion to susceptibility can occur over several years.

Flight activity is necessary for exposure to the active substance. In case of prolonged periods of low flight activity, e.g. due to unfavourable weather conditions efficacy may be reduced.

Success of treatment should be monitored with established standard tests like continuous monitoring of natural mite fall using a sticky insert tray, or assessing mite load per 100 bees to determine whether a winter treatment e.g. with oxalic acid is required.

Do not re-use bee-hive strip.

4.5 Special precautions for use

Special precautions for use in animals

After installation of the product bees may form clusters at the hive entrance for a couple of hours during adjustment.

Adequate ventilation of the hive should be ensured during high temperatures.

Polyvar Yellow has not been tested during periods of extremely hot weather. The product may impact hive ventilation to a similar extent as standard hive entrance reducers and thus should be temporarily removed if considered necessary.

Special precautions to be taken by the person administering the veterinary medicinal product to animals

Keep the bag with the bee-hive strips in the outer packaging until use.
Wash hands with cold water after fitting the bee-hive strips.

4.6 Adverse reactions (frequency and seriousness)

None.

4.7 Use during pregnancy, lactation or lay

Not applicable.

4.8 Interaction with other medicinal products and other forms of interaction

None known.

Do not use simultaneously with other acaricides against varroosis.

4.9 Amounts to be administered and administration route

In-hive use. Use at the bee-hive entrance as a gate.
Use two strips per standard bee-hive.

Application of the bee-hive strips:

Treatment should be started within a short time after honey flow and honey extraction to ensure sufficient flight activity for a treatment effect and healthy winter bee development. Treatment should be applied for at least 9 weeks until the end of flight activity but not longer than 4 months. In case of continuous mite fall at 9 weeks treatment should be continued. Thus treatment will usually cover the critical phase of potential horizontal mite transfer, e.g. by robbery. Treatment success should be monitored as mentioned in section 4.4.

The bee-hive strip should be fitted at the entrance in a way that the bees are forced to enter or leave the hive only through the holes of the strip. The entire surface and the holes of the bee-hive strip should not be covered to ensure the contact of the bees with the strip and to ensure ventilation of the hive. The strips are designed not to impair removal of dead bees. The strips should not be cut.

This pack only contains the bee-hive strips, however, depending on the bee-hive type and the size of the entrance further tools like tacks, staples, nails or blocks of wood may be needed to secure the strip in place. The strips can be fixed in different ways from the inside or outside of the hive.

For hive types with a wide entrance two strips can be fixed inline (see figure 3a, b for e.g. Boczonadi, Dadant, Deutsch normal, Langstroth, Simplex, Spaar-Kast and Zander hives).

For hives with a small entrance the strips can be fixed like a cuboid in front of the entrance (see figure 3c, e.g. Layens, A-Ž hives).

Examples are illustrated below.

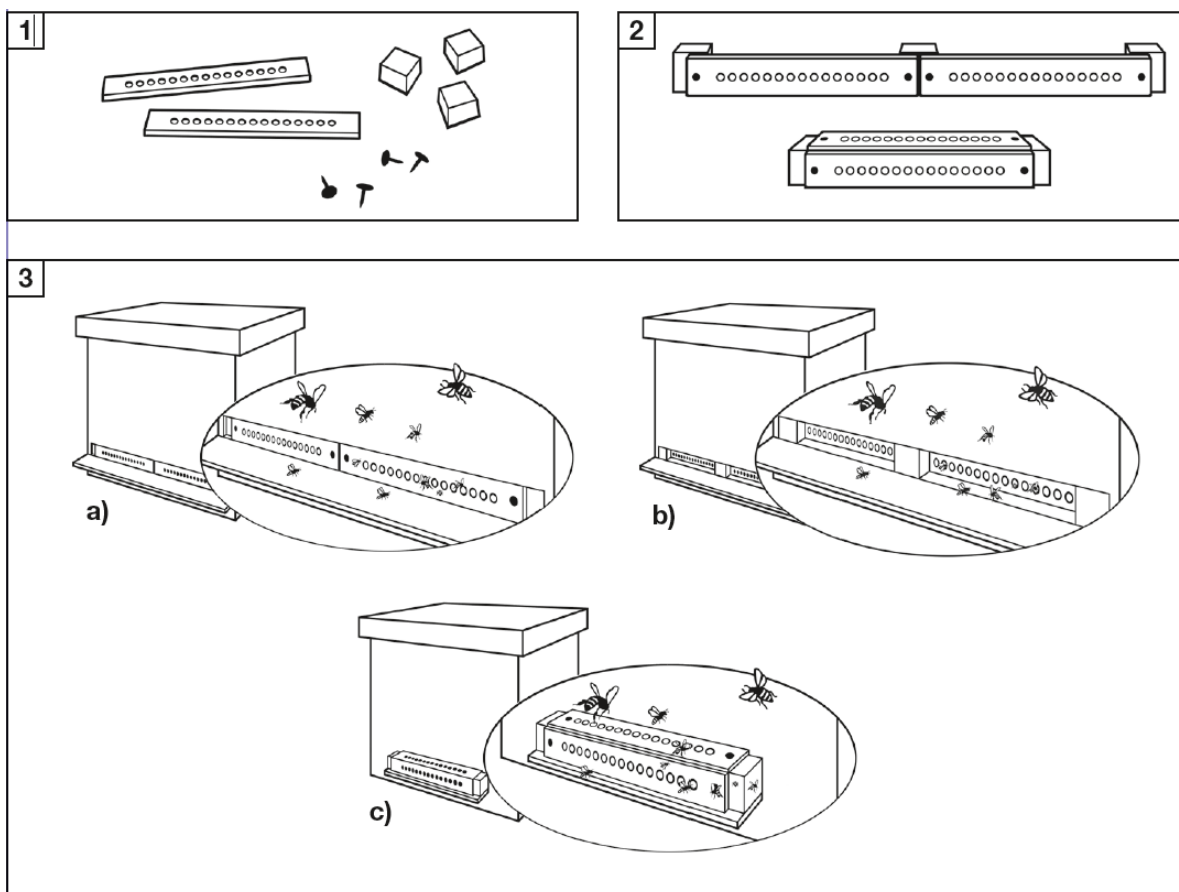

4.10 Overdose (symptoms, emergency procedures, antidotes), if necessary

Due to the nature of the bee-hive strips overdose is unlikely and signs of overdose are not to be expected.

4.11 Withdrawal period(s)

Honey: Zero days.

Do not use during honey flow.

5. PHARMACOLOGICAL PROPERTIES

Pharmacotherapeutic group: Ectoparasiticides for topical use, incl. insecticides, pyrethrins and pyrethroids
ATCvet code: QP53AC05.

5.1 Pharmacodynamic properties

Flumethrin is an ectoparasiticide of the synthetic pyrethroid group. According to current knowledge the synthetic pyrethroids interfere with the sodium channel of nerve cell membranes during excitation, resulting in long-lasting trains of repetitive firing and finally killing of the parasite. The α -cyano group on the phenoxy-fluorobenzyl alcohol moiety is considered to be responsible for the long-lasting prolongation of sodium permeability. In studies on structure-activity relationship of a number of pyrethroids interference with receptors of a certain chiral conformation was

noted thereby causing a selective activity on ectoparasites. No anti-cholinesterase activity was noted with these compounds.

There have been reports of pyrethroid resistance in varroa mites. Some cases have been attributed to alterations in the expression of certain detoxification enzymes, but the most common mechanism of resistance appears to be by mutations at the target receptor, the above mentioned sodium channel of nerve cell membranes.

In a field study performed using *Varroa destructor*-infested honey bee colonies, the genotypes of post-treatment residual mites ($\leq 5\%$ of the mite population since efficacy was $\geq 95\%$) were assessed for the presence of resistance-conferring mutations. Mites with a resistance mutation were detected in approximately 50% of the PolyVar Yellow treated colonies and in approximately 64% of colonies treated with another authorised pyrethroid. The mean percentage of homozygous resistant residual mites per colony was approximately 34% in PolyVar Yellow treated colonies and 49% in colonies treated with another authorised pyrethroid. Therefore, treatments should be rotated (as explained in section 4.4) in order to prevent further selection for resistance.

5.2 Pharmacokinetic particulars

Bees are exposed to the active substance by direct contact with the gate on entering and leaving the hive and indirectly by social contact inside the hive. There is no evaporation of active substance.

6. PHARMACEUTICAL PARTICULARS

6.1 List of excipients

Dibutyl adipate
Propylene glycol dicaprylocaprate
Epoxidised soybean oil
Stearic acid
Polyvinyl chloride
Titanium dioxide (E171)
Iron oxide yellow (E172)

6.2 Incompatibilities

None known.

6.3 Shelf life

Shelf-life of the veterinary medicinal product as packaged for sale: 5 years
Shelf life after first opening the immediate packaging: use immediately. Any remaining product should be discarded.

6.4 Special precautions for storage

This veterinary medicinal product does not require any special storage conditions.

6.5 Nature and composition of immediate packaging

Polyester/aluminium/ low density polyethylene foil bag

Pack size:

Box containing 1 foil bag (10 bee-hive strips)

Box containing 10 foil bags (100 bee-hive strips)

Not all pack sizes may be marketed.

6.6 Special precautions for the disposal of unused veterinary medicinal product or waste materials derived from the use of such products

Any unused veterinary medicinal product or waste materials derived from such veterinary medicinal product should be disposed of in accordance with local requirements.

PolyVar Yellow (strips or empty sachets) should not enter water courses as this may be dangerous for fish and other aquatic organisms.

7. MARKETING AUTHORISATION HOLDER

Elanco Europe Ltd.
Form 2, Bartley Way
Bartley Wood Business Park
Hook
RG27 9XA
United Kingdom

8. MARKETING AUTHORISATION NUMBER

Vm 00879/4146

9. DATE OF FIRST AUTHORISATION

07 March 2017

10. DATE OF REVISION OF THE TEXT

April 2021

Approved: 22/04/21

